

# *DRD 45*

## *Direct Reactance Drive 45 with tube rectification*

Assembly Manual

Designed by:

Jack Elliano

Ron Welborne



Copyright — 2005-2010 Welborne Labs

Welborne Labs reserve the right to periodically make changes and/or enhancements to this design.  
This manual may not be reproduced, in whole or part, in any form whatsoever, without the written permission of Welborne Labs.

## *Words of Caution*

Always keep in mind that you are the manufacturer of this amplifier. The final appearance of this amp and its sound quality will largely depend upon the care taken during the assembly of this kit. We recommend that your work surface be padded, clean of debris and kept clean during assembly. This will prevent the top plate and wooden base from becoming accidentally scratched. Keep finger prints to a minimum (wear white cotton gloves when handling the chassis plate). Once the transformers are mounted to the chassis plate, the unit becomes very heavy and much harder to handle. So be careful and don't drop it on your dining room table! Don't create antennas out of the hookup wire by making big loops and arches. Keep all wiring neat, lead lengths short and routed close to the chassis plate. Believe us when we say "neat wiring sounds mo better".

Always remember the nature of the equipment that you are working on. It contains high voltages and can cause serious personal injury. Always make sure that capacitors are completely discharged before handling or soldering the internal components. Never disconnect the power cord, or remove tubes while the unit is powered on.

## *Tools Required for Assembly*

Soldering Iron  
Solder  
Solder Wick™ or Solder-Removing Device  
Pliers  
Wire Strippers  
Hex Drivers  
Screw Drivers  
Volt/Ohm Meter  
Epoxy  
Cotton Gloves

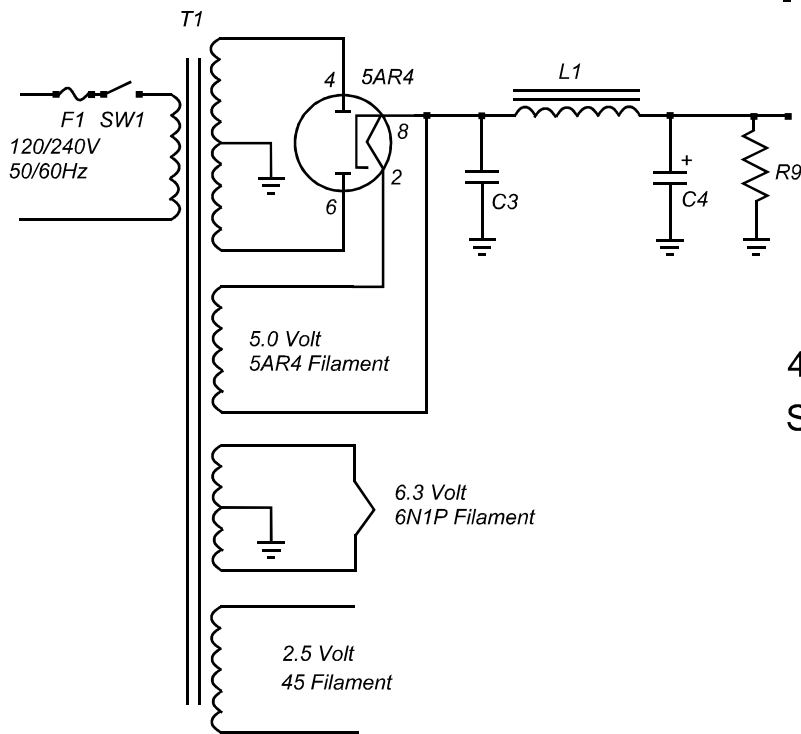
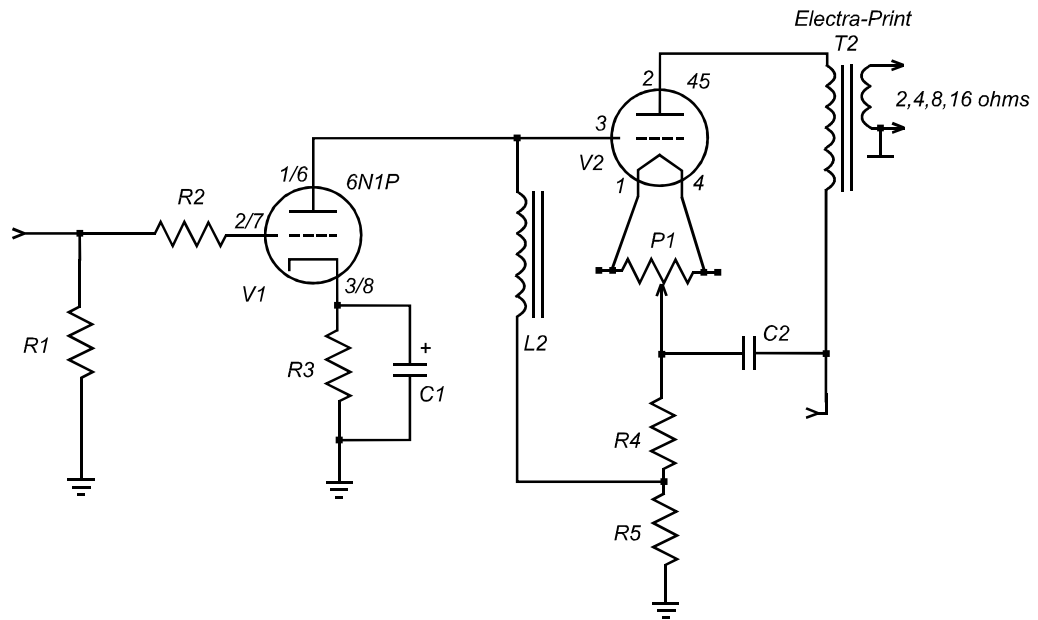

**45 DIRECT REACTANCE DRIVE  
SET Amplifier - Tube Rectification**

Copyright 2002, 2003 Electra-Print/Welborne Labs

## 45 DRD Parts List for Tube Rectification version (one channel shown)

_____	R1	100K	1% metal film resistor (caddock upgrade)	<p>Before you start, check the parts list against what as been included in your kit. Please inform us if you think anything is missing.</p>
_____	R2	100R	1% metal film resistor (caddock upgrade)	
_____	R3	332R	1% metal film resistor (caddock upgrade)	
_____	R4	1.0K	5W wirewound	
_____	R5	5.0K	25W wirewound	
_____	R9	330K	2W metal oxide	
_____	P1	100R	5W hum pot	
_____	C1	100uf	16V Elna Cerafine capacitor	
_____	C2	50uf	ASC Oil w/mtg. clamp upgrade	
_____	C3	15uf	600V Solen film capacitor	
_____	C4	100uf x 2	500V electrolytic capacitor with mtg. clamp	
_____	L1	20H	Electra Print power choke	
_____	L2	75H	Electra-Print plate choke	
_____	S1	9 pin	Tube socket	
_____	S2	4 pin	Tube socket	
_____	S3	8 pin	Tube socket	
_____	F1	1A	Fuse slo-blo, fuse holder & mounting screws	
_____	SW1	SPST	Power switch	
_____	IEC		IEC connector with mtg. hardware	
_____	SOL		Solder	
_____	H/W1		Transformer mounting screws, brass nuts, star washer and terminal ring	
_____	H/W2		Terminal strip standoffs and screws	
_____	H/W3		Rear panel brass screws	
_____	RCA		Cardas Phono jack	
_____	BIND		Cardas Binding Post	
_____	FEET		Rubber chassis feet	
_____	TB1		10 turret terminal strip	
_____	TB2		10 turret terminal strip	
_____	TB3		5 turret terminal strip	
_____	TB4		10 turret terminal strip	
_____	RP		Rear panel	
_____	ICORD		IEC power cord	
_____	Wire		Input Cable - red/black twisted pair ( Silver Wire - upgrade)	
_____	Wire		Solid core hookup wire - yellow, white, black (Silver Wire - upgrade)	
_____	Wire		Solid core bare silver wire	
_____	V1	6N1P	Input tube	
_____	V2	45	Output tube (not included with kit)	
_____	V3	5AR4	Rectifier Tube	
_____	T1		Custom power transformer	
_____	T2	5K	Electra-Print output transformer	

# *DRD 45 Assembly Procedures*

It is assumed that the person(s) assembling this amplifier kit are somewhat experienced with electronic kit building, assembly and soldering. If you do not have experience soldering circuits it is recommended that you find someone that can help that is knowledgeable (GET HELP!). These instructions and diagrams are intended as a guide only. You are welcome to assemble the amp and position components as you like. However, we recommend that you follow this assembly sequence. Refer to the included figures as you follow the instructions. Assembly time will vary based upon your experience level and the attention given to doing a neat and tidy job, so you can expect anywhere from 10 to 15 hours to get it done right. If you have questions during assembly, please feel free to call or email us.

Terminal boards have been provided to facilitate an easy and neat assembly. Solder components between terminals when possible (either vertically or horizontally) and use hookup wire from terminal-to-terminal and terminal-to-socket lug connections.

We have not finished the wood bases instead leaving this task for you do. Once you install the tube sockets, terminal boards, transformers, etc., via the following steps, you will remove the top plate from the wooden base. This is a good time to begin finishing the base so that chemical finishes can be drying while you assemble the electronics. C'mon, stop your griping! If Martha Stewart can finish wood, so can you. Here a few examples for wood finishes:

- A) Just apply an oil finish. Thinned linseed oil works good as do most furniture oils. I like to use a beeswax based furniture oil.
- B) Once you have oiled the wood you can leave it and periodically apply a new coat of oil once or twice a year. Or you can then apply a wax finish. My favorite brand is BRIWAX but there are hundreds of others that work well too. Two hand rubbed applications is generally sufficient for a durable coating. For a high gloss effect, use a bristle brush to burnish the wax finish. A horse hair shoe buffing brush works very well.
- C) Four or five hand rubbed coats of Danish Tung Oil will provide a very durable low maintenance finish.
- D) And lastly, you can always apply your favorite laquer or polyurathane finish to the wood bases.

Take a few minutes to familiarize yourself with the layouts of the chassis plates in figures 1 and 2. The two monoblocks are mirror images of each other. Please note that while terminal board “numbers” of TB1 and TB2 are “mirrored” the tube socket pins are not. The wiring shown on the figures appears somewhat messy. This is intentional as we have spread the wires out to make them more visible for your assembly process. As you assemble the wires and connections be a little bit neater with their layout. Route them close to the aluminum chassis plate and underneath the terminal boards and components. Do not make big airborne loops out of the wires as they will act as antennas and pickup noise, radio stations, etc. And be very careful with that soldering iron and don't burn the insulation off of any adjacent components.

1) To begin, remove the bottom black panels. Mount the tube sockets using the supplied hardware and in the direction shown in figures 1 and 2. The chassis plates are mirror images of each other and therefore as you continue through the assembly steps note that some components will have to mount differently on the opposite plate. If you are installing the Ultimate Upgrade package note that the teflon tube socket pins are not marked with numbers. Orient and install sockets V1 and V2 according to the key in the center of the socket. Note that tube socket V2 is not “keyed” but has two small diameter pins and two large diameter pins. The small diameter pins are 2 and 3. The large pins are 1 and 4. Orient and mount the socket according to the drawing.

Install the terminal boards TB1, TB2 and TB3 to the bottom side of the chassis as shown in Figures 1 and 2 using the supplied hardware. The black button head screws are used on the outside of the chassis and the silver screws on the inside. The lugs of the terminal boards TB1, TB2 and TB3 have been numbered (refer to figures 1 and 2) to facilitate assembly. In subsequent steps a specific lug will be referenced by the terminal board number followed by the lug number. For example the instructions: “solder a black wire from TB2-1 to TB1-14”, refers to lug #1 of terminal board TB2 and lug #14 of terminal board TB1.

In a similar manner, the tube socket pins will be referenced first by the tube number followed by the pin number. For example V2-3 refers to pin #3 of the V2 45 output tube.

Install fuse holder F1 to the chassis using the supplied hardware. Install resistor R5 to the chassis using the supplied hardware.

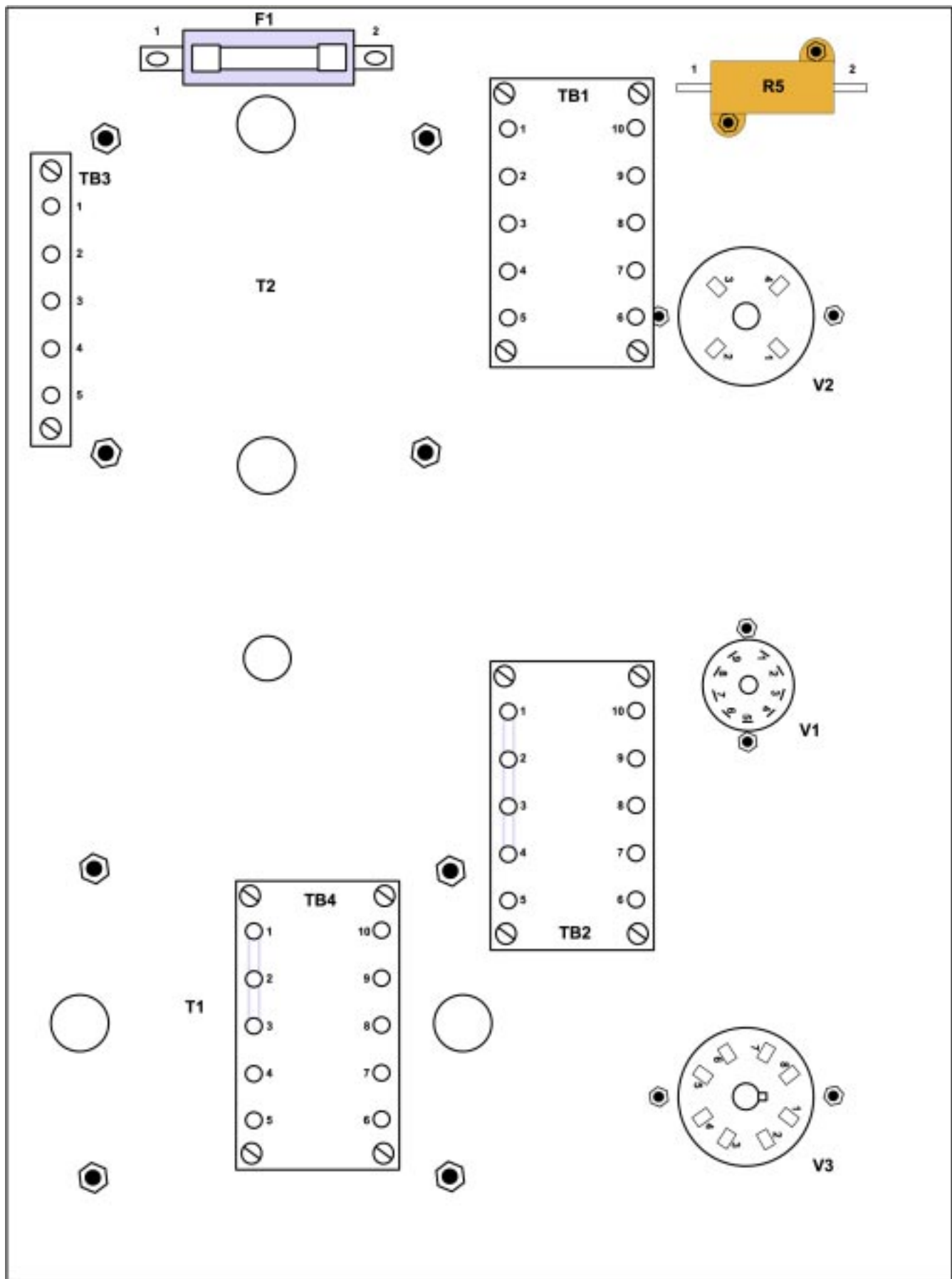

Figure 1

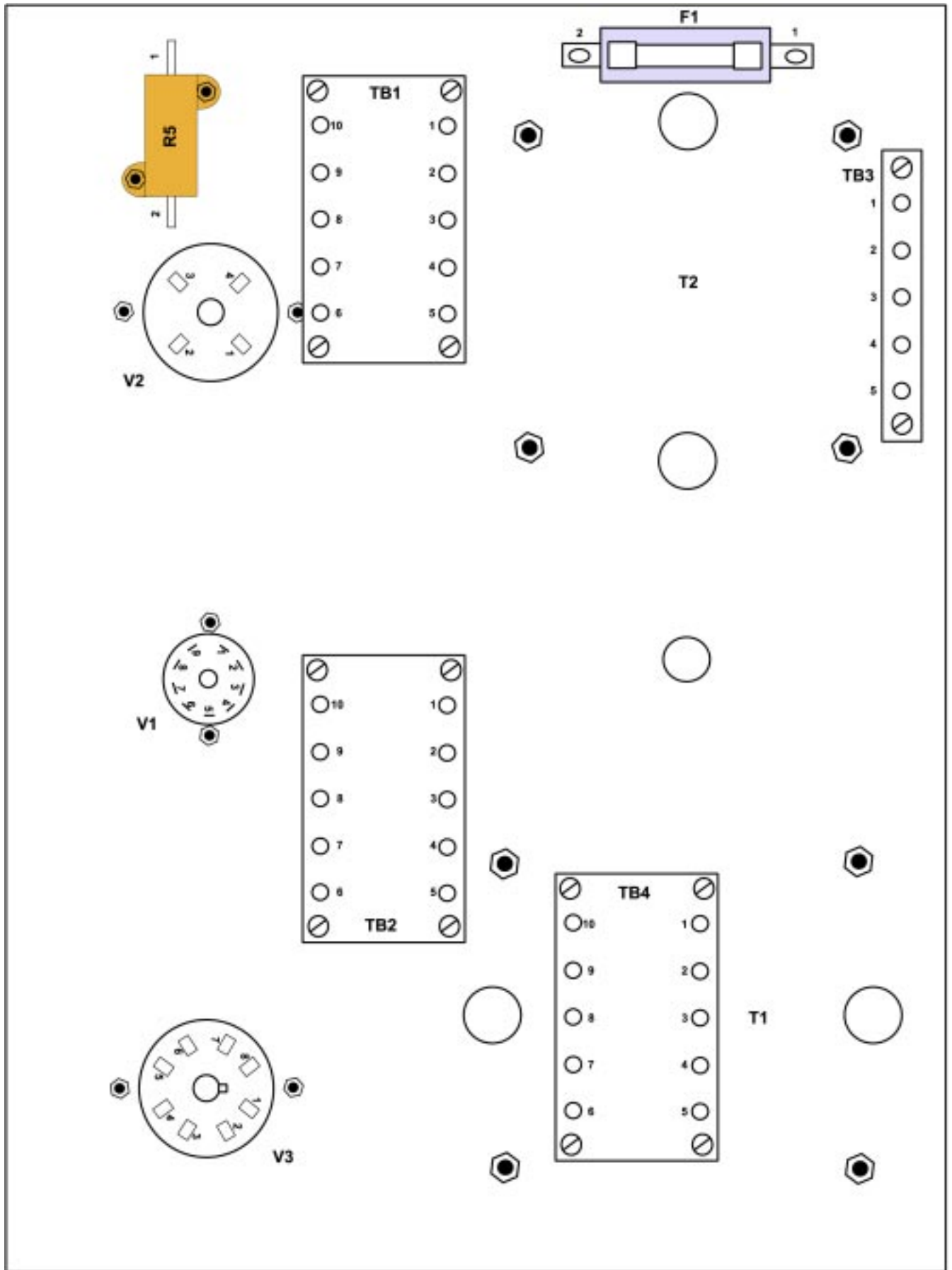

Figure 2

2) Mount the output transformer T2 and the power transformer T1 using the supplied hardware. It is generally easiest to do this by laying the chassis on a flat surface and feeding the transformer wires down through their respective holes. Referring to figure 3 and identifying the location of the transformer lead colors will give you an indication of which direction to orient the transformers when mounting them onto the top plate. **Be careful not to scratch the plate surface with the transformer edges or your tools.** Secure the transformers to the chassis using the button head screws, brass washers and brass nuts supplied in the plastic bag marked "H/W1".

Once the transformers are secured to the top plate, remove the top plate from its wooden base. Place the wooden bases out of the way (a good time to finish them). Turn the top plates upside down and lay the assembly on your work space such that they are resting on the transformers. Your workspace should have a padded surface to prevent the transformers from becoming scratched.

3) Begin by soldering all of the transformer leads to their respective terminals.

There are two blue leads from transformer T1. Twist these two leads together using approximately 2 twists per inch, route them as shown in figure 3, and solder one blue lead to V1-4 and the other lead to V1-5. These leads can also be routed under TB2.

Connect the blue with white striped lead of transformer T1 to TB4-2 as shown in figure 3.

There are two yellow leads from transformer T1. Twist together and solder one lead to V3-2 and the other one to V3-8.

There are two red leads from transformer T1. Twist together, route under TB4 and solder one red lead to V3-4 and the other one to V3-6.

Connect the red with yellow striped lead of transformer T1 to TB4-3.

There are two green leads from transformer T1. Twist these two leads together using approximately 2 twists per inch, route as shown in figure 3, and solder one green lead to P1-1 and the other lead to P1-3.

Locate the green and white striped lead from T1. Cut this lead short as it will not be used. The end of the lead can be taped or covered with heat shrink tubing.

4) Connect the T1 transformer primary leads based upon your ac voltage requirements. Refer to figure 3 and the instructions below (figure 3 depicts a 120Vac connection).

For **120Vac/60Hz** operation hookup the T1 primary as follows:

Locate the brown, brown/white, black and black/white leads of transformer T1. Twist the brown and brown/white leads together using approximately 3 twists per inch and solder to TB3-5. Trim to an appropriate length the black and black/white leads, strip the ends and solder to TB3-4. Cut the orange wire to a length of approximately 1 inch and tape the end using electrical tape or cover with heat shrink tubing.

For **220Vac/50Hz** operation hookup the T1 primary as follows:

Solder the black and brown/white leads together and tape their ends or cover with heat shrink tubing. Connect the black/white lead wire to TB3-5. Trim to an appropriate length, strip the ends and solder to the lug. Solder the orange wire to TB3-4. Cut the brown wire to a length of approximately 1 inch and tape the end using electrical tape cover with heat shrink tubing.

For **240Vac/50Hz** operation hookup the T1 primary as follows:

Solder the black and brown/white leads together and tape their ends or cover with heat shrink tubing. Connect the black/white leadwire to TB3-5. Trim to an appropriate length, strip the ends and solder to the lug. Solder the brown lead wire to TB3-4. Cut the orange wire to a length of approximately 1 inch and tape the end using electrical tape or cover with heat shrink tubing.

For **100Vac/50Hz** operation hookup the T1 primary as follows:

Solder the brown and brown/white leads together and tape their ends or cover with heat shrink tubing. Twist together the black and black/white leads and solder them to TB3-5. Solder the orange wire to TB3-4.



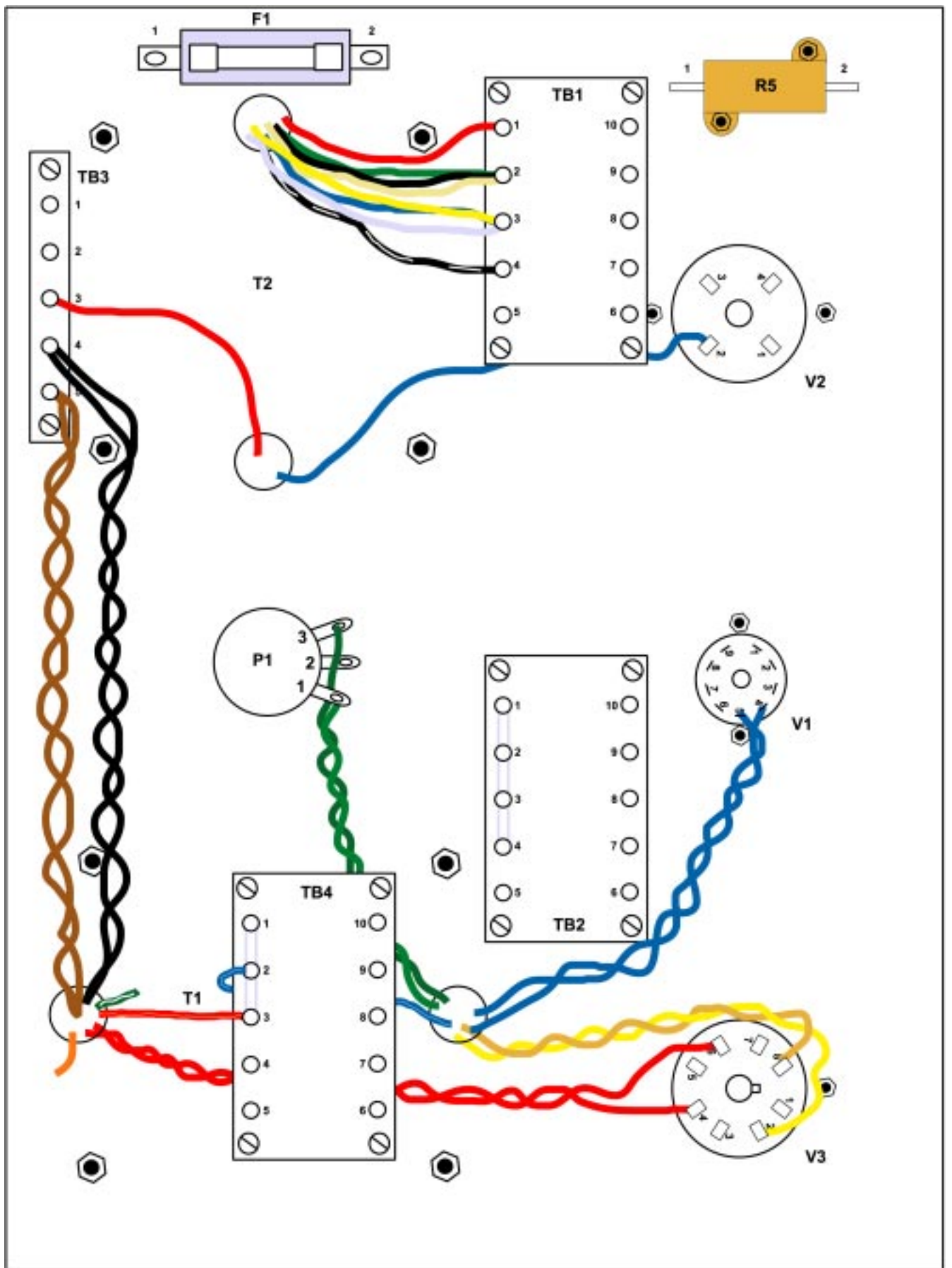

Figure 3

5) Connect the red lead of transformer T2 to TB3-3. Connect the blue lead of T2 to V2-2.

You now must decide which tap of the output transformer T2 you will be using (2, 4, 8 or 16 ohms). This decision is best made based upon the impedance of the speakers you will be using.

Refer to the table below for the output transformer coding. The output impedances are selected by interconnecting the eight color coded **secondary** leads as shown below. Figure 3 depicts the connection for 8 ohms, however the terminals of TB1 can be used for connecting any of the configurations below. If you decide to shorten the output leads of the transformer T2, the red enamel coating on the wires must be removed before soldering to the terminals. This can be easily done by scraping with a razor blade.

**16 OHMS**

R - Output  
Join BK, CL  
Join WH, GR  
Join BL, Y  
BW - Ground

**8 OHMS**

R - Output  
Join BK, CL, GR  
Join WH, BL, Y  
BW - Ground

**4 OHMS**

Join BK, R - Output  
Join WH, BL, BW, Y  
Join CL, GR - Ground

**2 OHMS**

Join BK, WH, BL, R - Output  
Join BW, CL, GR, Y - Ground

Join the leads by soldering them to the terminals of TB1.

Secondary wire color code:	
BW - Black w/White Letters	GR - Green
BK - Black	BL - Blue
CL - Clear	Y - Yellow
WH - White	R - Red

Locate the bare uninsulated silver wire. Wrap a piece of the wire tightly around terminals TB2-1, TB2-2, TB2-3 and TB2-4 as shown in figure 3. Wrap another piece of the wire tightly around terminals TB4-1, TB4-2 and TB4-3 as shown in figure 3. Now make a solder connection between each of the terminals and the wires.

If you haven't already done so, repeat the above steps 1-5 for both amplifiers. Now this is where you earn your wings because the remaining drawings in this manual only depict one of the amplifiers and while this drawing doesn't exactly match its mirror image mate you should be able to complete the other amplifier without an exact drawing to go by. Just remember that terminal boards TB1, TB2 and TB4 are mirrored, but the tube socket "pins" are not mirrored. Refer back to figure 2 if you get confused. Some people build one amp first, test it, and then go back and build the second amplifier. Others build both amps at the same time. I personally prefer to build both amps together. Just take your time and follow the instructions.

6) Cut a piece of the black hookup wire to length and solder one end to TB4-1 and the other end to TB2-4. Route the wire under TB4 as shown in figure 4.

Cut a piece of the yellow hookup wire to length and solder one end to TB4-10 and the other end to V3-8 As shown in figure 4.

Locate the bag marked "H/W1" and remove one ring terminal, a star washer and a brass nut. Cut a piece of the black wire to a length of approximately 10 inches. Solder one end of this wire to TB4-1 as shown in figure 4. Trim the wire to length and solder the ring terminal to the other end of this wire. You will now attach this ring to the transformer bolt as shown in figure 4. First remove the nut that secures the transformer mounting bolt. Install the star washer onto the bolt and then re-install the nut and tighten securely so that the star washer digs into the bottom of the aluminum plate. Now place the ring terminal onto the bolt and secure with the brass nut. Just finger tighten this nut for the time being. The ring terminal should now be sandwiched between the two brass nuts.

Cut a piece of the black hookup wire to length and solder one end to TB3-4 and the other end to F1-1 as shown in figure 4.

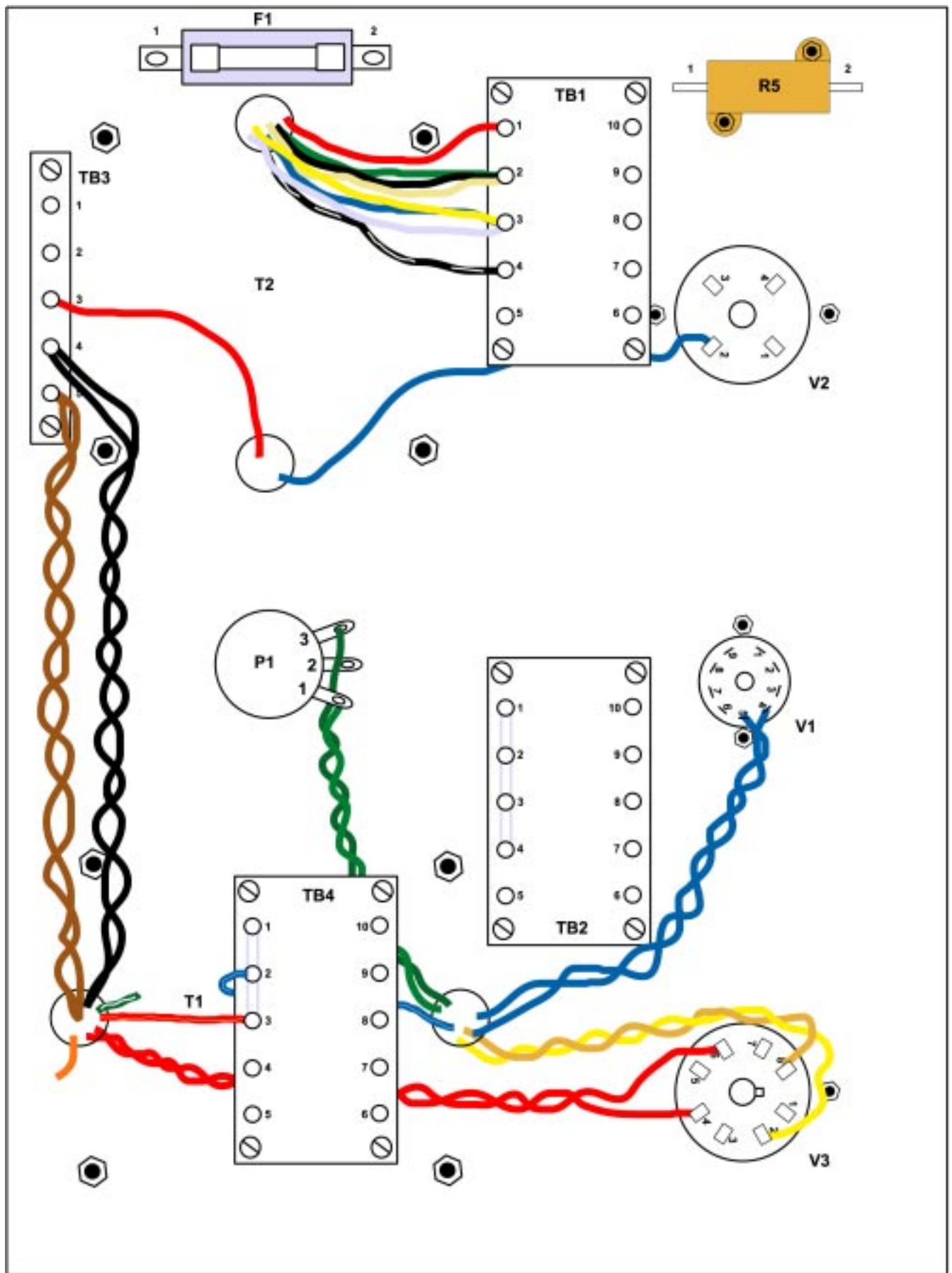

Figure 3

Cut a piece of the black hookup wire approximately 6 inches in length and solder one end to TB4-2 and leave the other end unconnected at this time.

Cut a piece of the black hookup wire to length and solder one end to TB1-4 and the other end to TB2-2. Route the wire under terminal board TB1 as shown in figure 4.

Cut a piece of the black hookup wire to length and solder one end to R5-1 and the other end to TB2-1. Route the wire under terminal board TB1 as shown in figure 4.

Cut a piece of the yellow hookup wire to length and solder one end to P1-2 and the other end to TB1-6. Route the wire as shown in figure 4.

Cut two pieces of yellow hookup wire to length, solder one wire to P1-1 and the other wire to P1-3. Twist them together, route as shown in figure 4 and solder the other ends of these wires to V2-1 and to V2-4.

Cut a piece of the yellow hookup wire to length and solder one end to TB1-10 and the other end to TB2-5. Route the wire under terminal boards TB1 and TB2 as shown in figure 4.

Cut a piece of the yellow hookup wire to length and solder one end to R5-2 and the other end to TB1-10. Route the wire as shown in figure 4.

Cut a piece of the yellow hookup wire to length and solder one end to V2-3 and the other end to TB2-6. Route the wire under terminal boards TB1 and TB2 as shown in figure 4.

Cut a very short piece of the yellow hookup wire and solder one end to V1-1 and the other end to V1-6.

Cut a very short piece of the yellow hookup wire and solder one end to V1-2 and the other end to V1-7.

Cut a very short piece of the yellow hookup wire and solder one end to V1-3 and the other end to V1-8.

Cut a piece of the yellow hookup wire to length and solder one end to V1-8 and the other end to TB2-8. Route the wire as shown in figure 4.

Cut a piece of the yellow hookup wire to length and solder one end to V1-7 and the other end to TB2-9. Route the wire as shown in figure 4.

Cut a piece of the yellow hookup wire to length and solder one end to V1-6 and the other end to TB2-6. Route the wire as shown in figure 4.

Cut a piece of the yellow hookup wire to length of approximately 9 inches and solder one end to TB3-3. Route the wire as shown in figure 4 leaving the other end unterminated at this time.

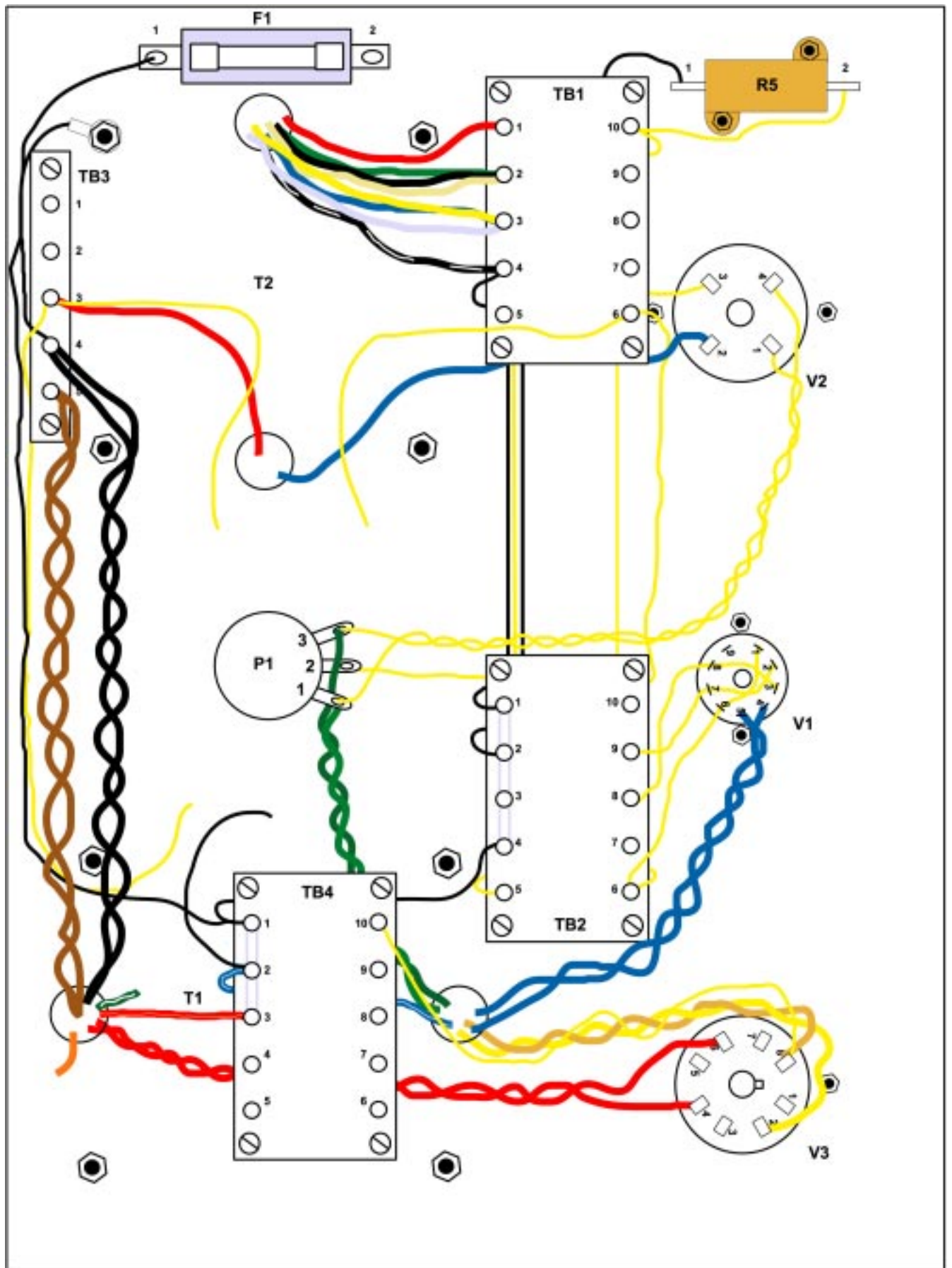

Figure 4

7) Now is a good time to inspect all connections and clean up any solder flux that may have splashed onto the terminal boards, top plate, etc. As the amplifier is populated with more components it becomes more difficult to position the soldering iron without touching already placed parts. It is very important that you be aware of these parts when soldering and not accidentally burn the insulation off an adjacent component or wire. For this next section, refer to figure 5 for all connections.

Solder resistor R1 between TB2-1 and TB2-10 as shown in figure 5.

Solder resistor R2 between TB2-10 and TB2-9 as shown in figure 5.

Solder resistor R3 between TB2-3 and TB2-8 as shown in figure 5.

Solder resistor R4 between TB1-10 and TB1-6 as shown in figure 5.

Solder capacitor C1 between TB2-3 and TB2-8 as shown in figure 5. Note C1 capacitor is polarized. The capacitor lead adjacent to the band on the body of the capacitor is the negative lead and should be soldered to TB2-3.

Solder capacitor C3 between TB4-1 and TB4-10 as shown in figure 5. C3 is not polarized.

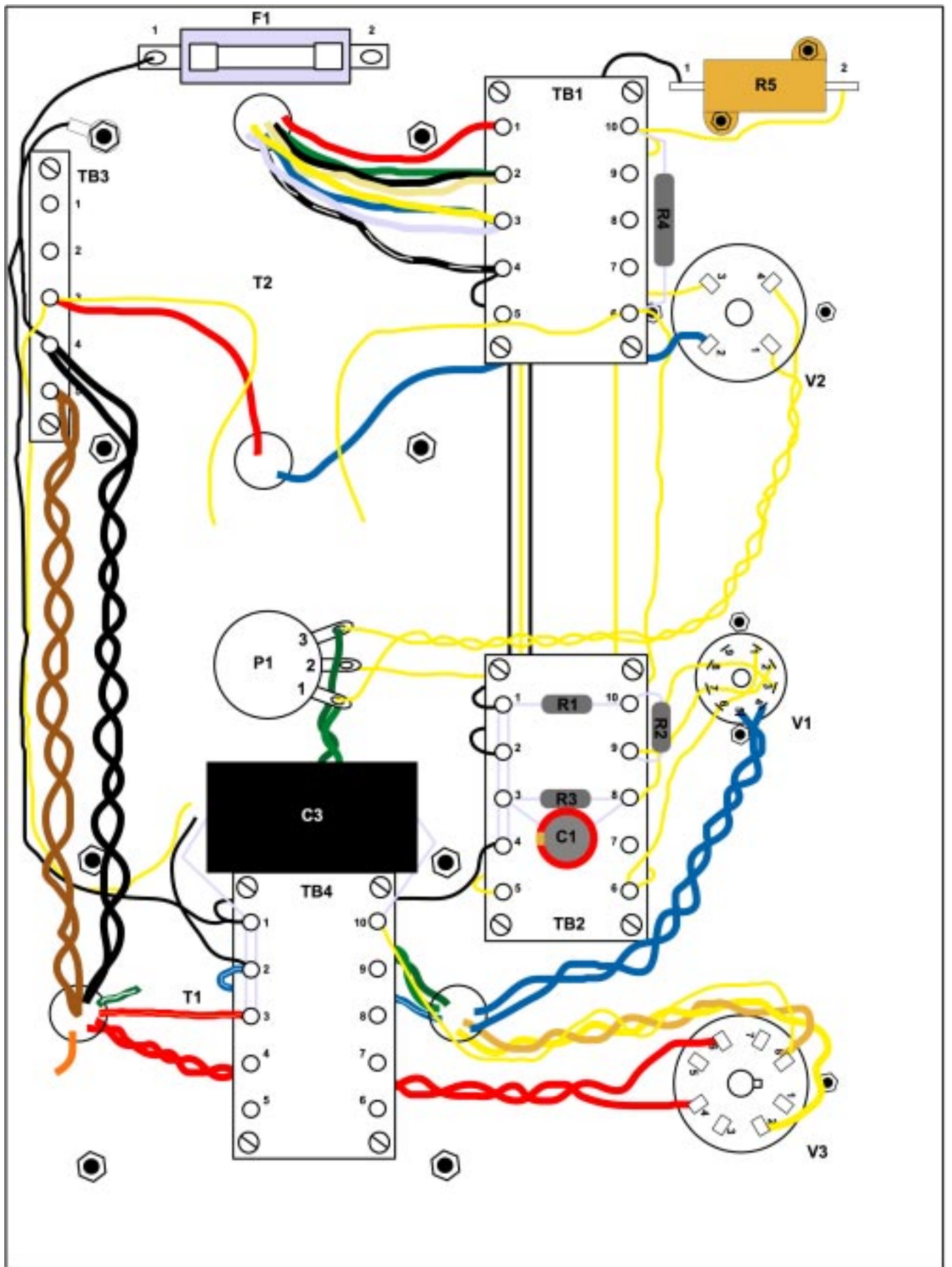

Figure 5

8) Carefully attach the wood chassis to the top plate using the 4 black button head screws.

Route the two leads of inductor L1 (you can twist them together), cut to proper length and solder one lead to TB4-10 and the lead to the positive “+” terminal of capacitor C4.

Solder a short yellow wire between the two positive “+” terminals of capacitor C4.

Solder the yellow wire that was previously attached to TB3-3 to the other positive terminal of capacitor C4.

Solder the black wire that was previously attached to TB4-2 to the negative “-” terminal of capacitor C4.

Locate the bag marked “R9” and solder this resistor between the positive and negative terminals of capacitors C4 as shown in figure 6.

Route the two leads of plate choke L2 (you can twist them together), cut to proper length and solder the orange lead to terminal TB2-5. Solder the purple lead to terminal TB2-6 as shown in figure 6.

Solder the two yellow wires previously attached to TB1-6 and TB3-3 to the terminals of capacitor C2 as depicted in figure 6. This capacitor is not polarized.

9) This is the final phase of the assembly process. Refer to figures 7 and 8 for this phase.

Locate the bag marked “RCA”. Using the red/black twisted pair hookup wire, cut a piece approximately 12” long. Strip off approximately 1/8 inch of the red wire’s insulation and solder this wire to the center lug of the rca jack. Solder the black wire to the rca ground plate on the back of the jack.

Locate the bag marked “BIND”. Cut a piece of yellow hookup wire approximately 4 inches in length and solder this wire inside the hollow shaft of one of the binding posts. Make sure you do not get solder on the outside threaded surface of the shaft. If you are using a small pencil iron, it will take some time to heat up these posts and melt the solder, so be patient. **CAUTION: These posts will be extremely hot once you’ve soldered them...DO NOT TOUCH! Allow the posts to cool for about 5 minutes before handling.**

Cut a piece of black hookup wire approximately 5 inches in length and solder this wire inside the hollow shaft of one of the binding posts. Allow to cool.



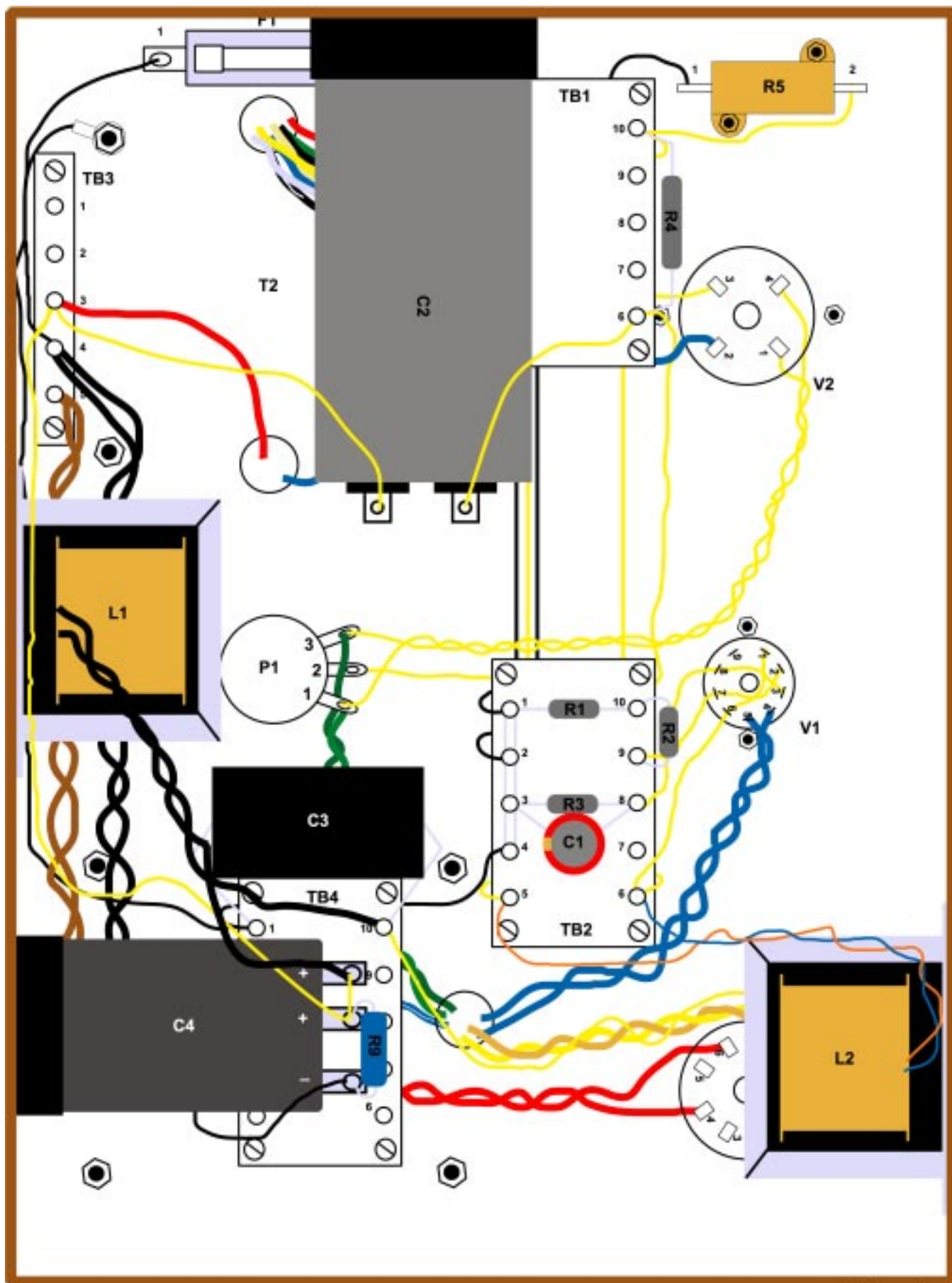

Figure 6

Locate the two black rear panels. Note these panels are mirror images of each other. Mount the power switches SW1 and IEC connectors to these rear panels as shown in figure 7.

Cut a piece of black hookup wire approximately 4 inches in length and solder a terminal ring to one end and then solder the other end of the loose wire to terminal 1 of the IEC connector as shown in figure 7.

Cut a length of black hookup wire approximately 8 inches in length and solder one end to terminal 3 of the IEC connector. Cut a short length of wire and solder it between terminal 2 of the IEC connector and terminal 2 of the power switch SW1. Cut a 6 inch length of black hookup wire and solder it to terminal 1 of the power switch SW1.

Mount the rca jacks and binding posts to the rear panels. The insulating washers should be used with both the rca jacks and binding posts. Red is positive and black is negative for the binding post washers.

**10)** Mount the plate containing the rca jacks and binding posts to the wood base and secure it with the brass screws. Be careful not to strip the heads of the brass screws or scratch the rear panel.

Solder the black wire attached to terminal 1 of the power switch SW1 to F1-2. Solder the black wire attached to terminal 3 of the IEC connector to TB3-5.

Place the black wire with the ring terminal end over the mounting stud of T2, as shown in figure 8, and secure with a brass nut.

As shown in figure 8, cut the red and black twisted wires to length and solder the red wire to TB2-10. Solder the black wire to TB2-1.

Route the black wire, attached to the negative binding post, under terminal board TB1 and solder the loose end to TB1-4.

Solder the yellow lead attached to the positive binding post to TB1-1 (8 ohms).

Install the fuse in the fuseholder F1.

This completes the assembly phase of the DRD 45 amplifier. Now is a good time to go back and check and double-check your work. This can be very tedious but it can also save time and money if you find your errors now instead of later. Of course applying power to the unit is usually the fastest way to find out your mistakes...just look for the smoke...but not the cheapest or best way!

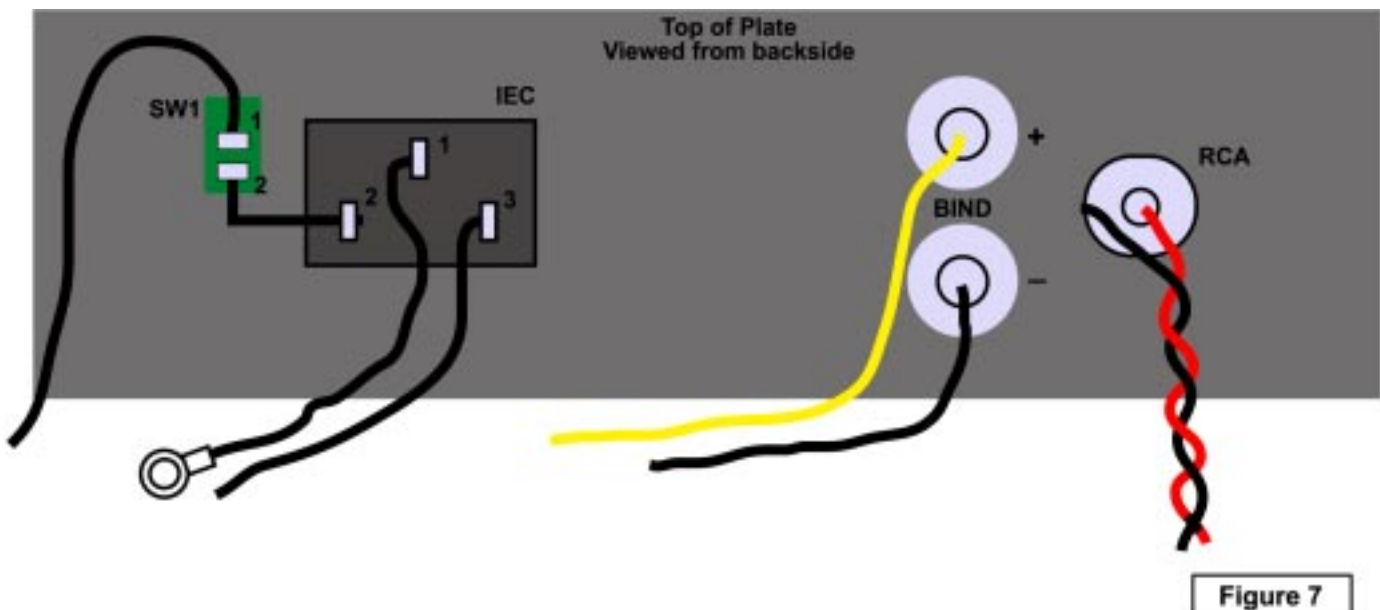

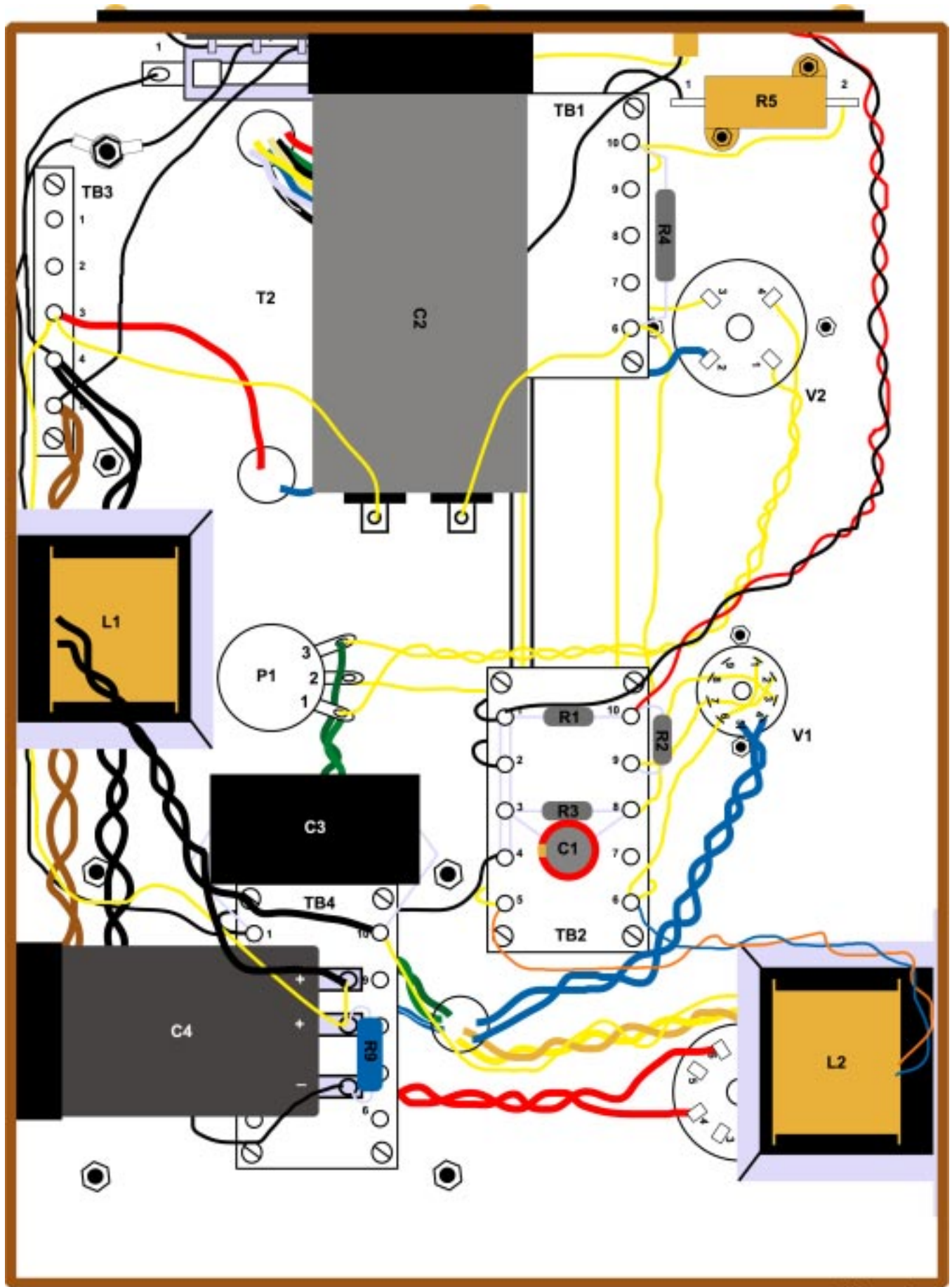

Figure 8

# Power Up and Test Instructions

## Power-up Sequence

1) It is recommended that you connect the amplifier to a dummy load or **old** set of speakers during the power-up procedure. The amplifier must have tubes installed to power-up and test operation.

2) If you own or have access to a variable ac transformer, use it to slowly increase the ac voltage during power-up. Monitor the high voltage, using a dc voltmeter, as you increase the ac voltage. If you do not have access to variable transformer, use the voltmeter to measure the high voltage as you power-up the amplifier. If the high voltage does not show signs of increasing after 4 or 5 seconds, immediately turn off the power. To measure the high voltage connect the red or positive lead of your voltmeter to the positive terminal of capacitor C4. Connect the negative or black lead of your voltmeter to the negative terminal of capacitor C4. Set the voltmeter for a "DC Volts" reading and for a voltage range of 600 volts or more. Upon full power you should measure approximately 470 volts. This value may vary by as much as plus or minus 20 volts depending upon the ac line voltage in your area.

If the high voltage checks OK, next measure the voltage across resistor R5. Connect the positive lead of your voltmeter to R5-2 and the negative lead of the meter to R5-1. Set the voltage range on the meter to the 400 volt dc scale or higher. You should measure approximately 160 volts. This value may vary by as much as plus or minus 10 volts.

Next check the 45 filament voltage. Set your meter to measure ac voltage and connect one lead to P1-1 and the other lead to P1-3. You should measure approximately 2.5 volts plus or minus a few tenths of a volt.

Next set your meter to measure ac voltage and connect one lead to V1-4 and the other lead to V1-5. You should measure approximately 6.3 volts.

3) If all the above voltages measure OK, and you are connected to a set of speakers, listen for excessive noise, oscillations or hum. Use the hum pot to null out the hum. You can do this by listening to the hum through a set of speakers and adjusting the pot for minimum hum, or you can set your meter for ac voltage and measure at the output posts and adjust for minimum voltage. With the input of the amplifier shorted, you should be able to adjust the hum for less than 1mVolt.

4) If there is no excessive noise, you are now ready to give the amps a listen.

## Troubleshooting

**Problem:** Low or no high voltage      Check the polarity of all electrolytic capacitors.

**Problem:** No Sound                      Are the tubes glowing? Are your speakers properly connected?

**Problem:** Excessive Hum              Possible ground loop in circuit or chassis may not be grounded. Check all ground wiring. Check filament voltages and wiring. Check all tubes.

**Problem:** Popping Noise              Possible cold or weak solder joint or loose connections. Check all solder connections.

If you have difficulty troubleshooting your equipment, give us a call. We will be glad to help you get your equipment running. We have a very high success rate at troubleshooting equipment problems over the telephone however phone calls can be expensive and they will be on your nickel, not ours. A letter or e-mail might be more appropriate, but in either case it will help if you have taken the time to write down as many symptoms as possible and also take and record some voltage measurements at key nodes in the circuit. If all else fails, you can send your amplifier to us, however this should be your last resort.

We have built and tested this amplifier and it works and therefore we have to assume that if your amplifier does not work, it is most likely something you did wrong during assembly. We charge a flat rate of \$35 per hour for repairs.

# *Final Notes*

Several different types of tubes can be used with your DRD amplifier. The most obvious is the 45 tube. You can safely use NOS 45s and new production models.

Allow the amplifiers to warmup for several minutes prior to using them. This will guarantee the amps are operating under optimum conditions. One note: the DRD amplifiers are designed to be “very quiet” with respect to ac hum. Even with speakers in the 105dB sensitivity range, no hum should be audible from your listening position and maybe only a faint hum with your ear near the speakers. If you experience hum with your DRD monoblocks, go back and revisit the ground wiring. Did you follow our wiring diagram exactly? 99.9% of the time, hum can be attributed to a ground problem, so this is the place to look first. Did you adjust the hum pots for minimum noise?

The DRD amplifiers are designed to require a minimum amount of maintenance. There are no adjustments to make, you just plug in the tubes, turn on the power and enjoy. A light application of a window cleaner, such as Windex, can be used to remove dust and dirt from the aluminum plates.

No doubt many of you will look at this amp with an eye on making component changes or circuit modifications. If you purchased this amplifier pre-assembled, this will void the warranty. If you have built the kit version, then go for it!

Have fun with your experimentation and listening. I hope you receive many years of enjoyment from your purchase.

Peace and Happiness,

A handwritten signature in black ink, appearing to read "Ron Welborne". The signature is fluid and cursive, with a long horizontal stroke at the end.

Ron Welborne  
Welborne Labs